

## SINGLE-PORTED GLOBE CONTROL VALVES TYPE S

### APPLICATIONS:

Single-ported globe control valves type S are used in automatic and remote control systems to control flow of gases and liquids. Wide range of material and design versions make the valves widely sought-after in chemical industry, heat and power generation industry, paper industry, food industry, metallurgy and coal mining.

### CHARACTERISTICS:

- range of nominal sizes from DN15 to DN250 for pressure values PN10 to CL300,
- various materials of valve body cast and internal parts, adapted to specific working conditions,
- wide range of flow ratios and control characteristics,
- reduction in aggressive and toxic media emissions to environment through application of bellow seal bonnets or bonnet packings meeting requirements of TA - LUFT,
- easy assembly and dismantling of valve internal parts for maintenance and service,
- high durability and reliability due to application of top-class materials and surface improvement processes (burnishing, stellite, heat treatment, CrN coatings),
- possibility of mating with reversible action P/R (column) multi-spring actuators and changing the spring range with no extra parts (keeping the number of springs),
- possibility of fitting actuators with top drive,
- possibility of performing diagnostics of "valve-actuator" system due to application of smart electro-pneumatic positioners,
- high tightness of closure due to application of soft valve seats (with PTFE seals in the whole range of flows and characteristics, for valve plugs, balanced and unbalanced,
- same flow ratios and control characteristics for "hard" valve seats (metal-to-metal) and "soft" valve seats (metal-gasket), for valve plugs, balanced and unbalanced,
- reliable actuator-stem and valve seat-body connections,
- small guiding sleeve control forces due to application of balanced valve plugs in valves DN40...250,
- top-class flat and bonnet packings,
- wide range of electric actuators,
- possibility of mating with NN type hand operated drives,
- possibility of special executions for oxygen, hydrogen, gas fuels, low temperature mediums (liquid oxygen, liquid nitrogen), acid gases containing H<sub>2</sub>S; explosive atmospheres as per 94/9/EC - ATEX,
- competitive prices – due to simple and functional design of valves and actuators and applied materials,
- design and production process meets the requirements of Quality Management System ISO 9001 and Directive 97/23/EC, and regulations of AD2000 Merkblatt, designated for installation on pipelines,

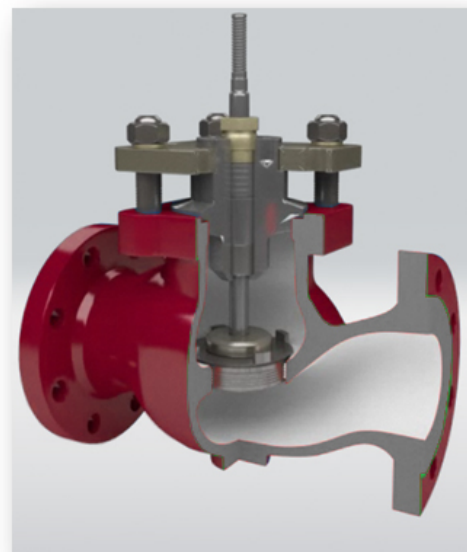

**DESIGN AND TECHNICAL SPECIFICATION:**

**Body (1):** single-ported, flanged, cast in cast iron or cast steel.

Nominal sizes: DN15; 20; 25; 32; 40; 50; 65; 80; 100; 125\*); 150; 200; 250

\* special execution, technical data according to individual inquiries.

Nominal pressure: PN10; 16; 25; 40 (as per PN-EN 1092-1:2010 and PN-EN 1092-2:1999); CL150; CL300 (as per PN-EN 1759-1:2005).

Steel flanges CL150; CL300 are so designed that they can be assembled with flanges executed per American standards ANSI/ASME B16.5 and MSS SP44. In American standards flanges are identified with nominal values in "Classes", to which nominal pressure (PN) values as per PN-ISO 7005-1:2002 correspond.

Equivalent identification as per PN are: CL150: PN 20 and CL300: PN 50.

Table 1. Flanged end connections

Material	Nominal pressure	Facing of flange types			
		Raised face	Groove	Recess	Ring - joint
Identification					
Grey iron	PN10; 16	B <sup>2)</sup>	-	-	-
Spheroidal iron	PN10; 16; 25; 40		-	-	-
Cast steel	PN10; 16; 25; 40		D	F	-
	CL150		-	-	J (RTJ)
CL300	DL ( D1 <sup>1)</sup>	F ( F1)			
<sup>1)</sup> - only for CL300; <sup>2)</sup> - B1 - (Ra=12.5 mm, concentric surface structure "C"), B2 - (Ra as agreed with the customer); () - identification of connections as per ASME B16.5					
Possible execution of flanges per specification and indicated standards					

Face-to-face dimensions: as per PN-EN 60534-3-1; 2000r. - Fig. no. 7 ; Table 19 and 20. Series 1 - for PN10; 16; 25; 40; series 37- for CL150; series 38 - for CL300

**Bonnet (2)** - non-cast - assembled to body via assembly plate (DN15-100)  
 - cast (DN150-250): a) standard, b) extension (for cast steel valves),  
 c) bellows (for cast steel valves).

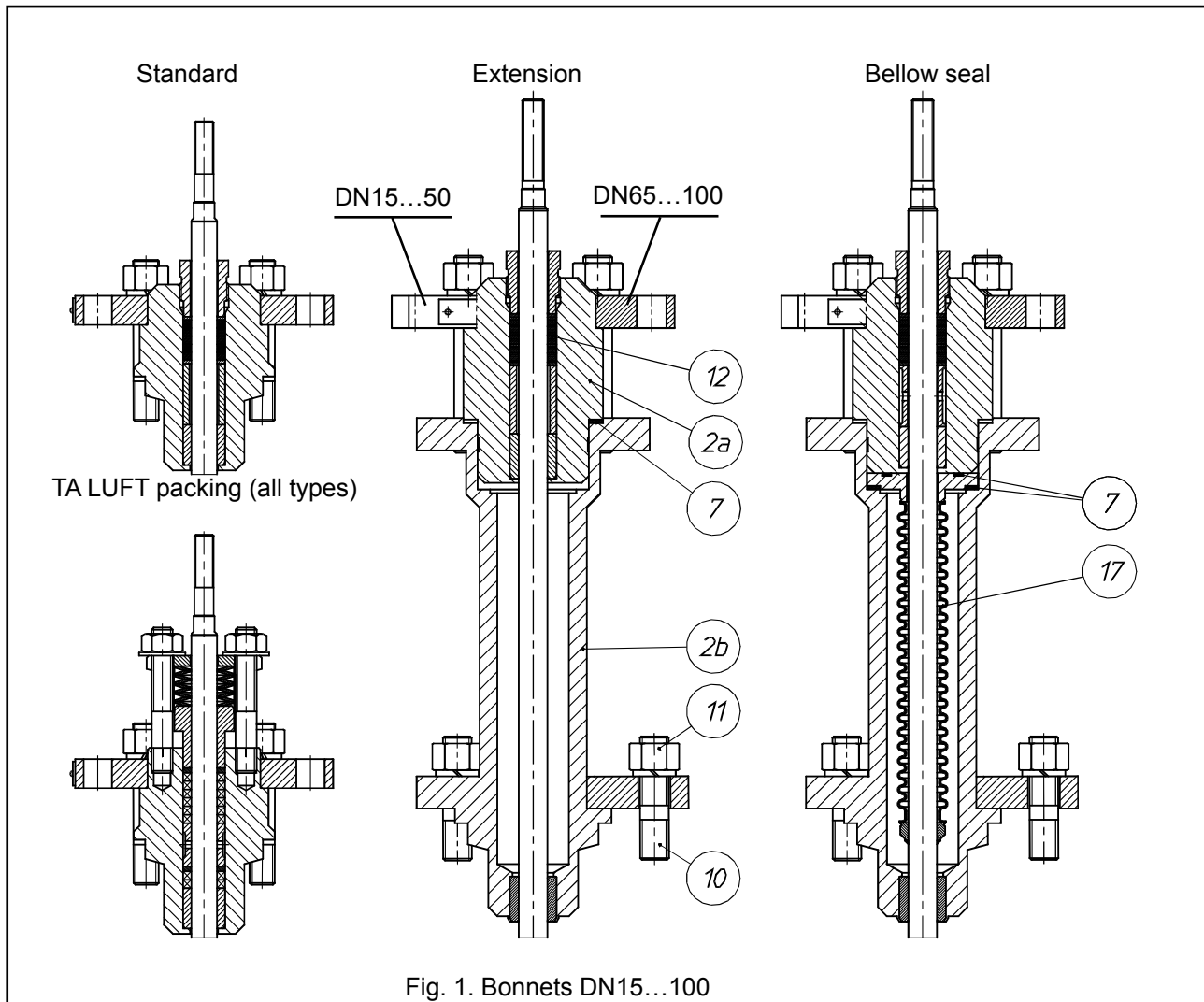

Fig. 1. Bonnets DN15...100

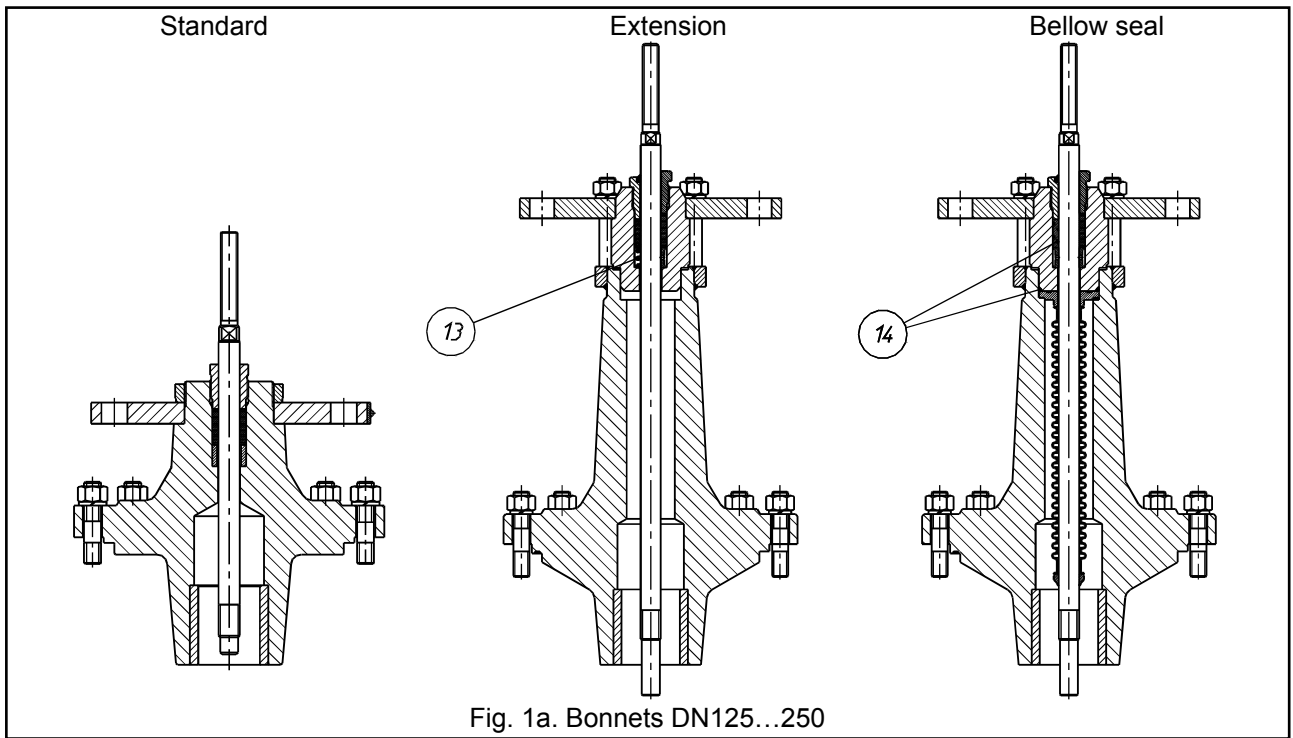

Fig. 1a. Bonnets DN125...250

**Valve plug (3) - contoured, balanced, unbalanced**

- control characteristics:
  - linear (L)
  - equal percentage (P)
  - quick-opening (S)
- rangeability:
  - 50:1

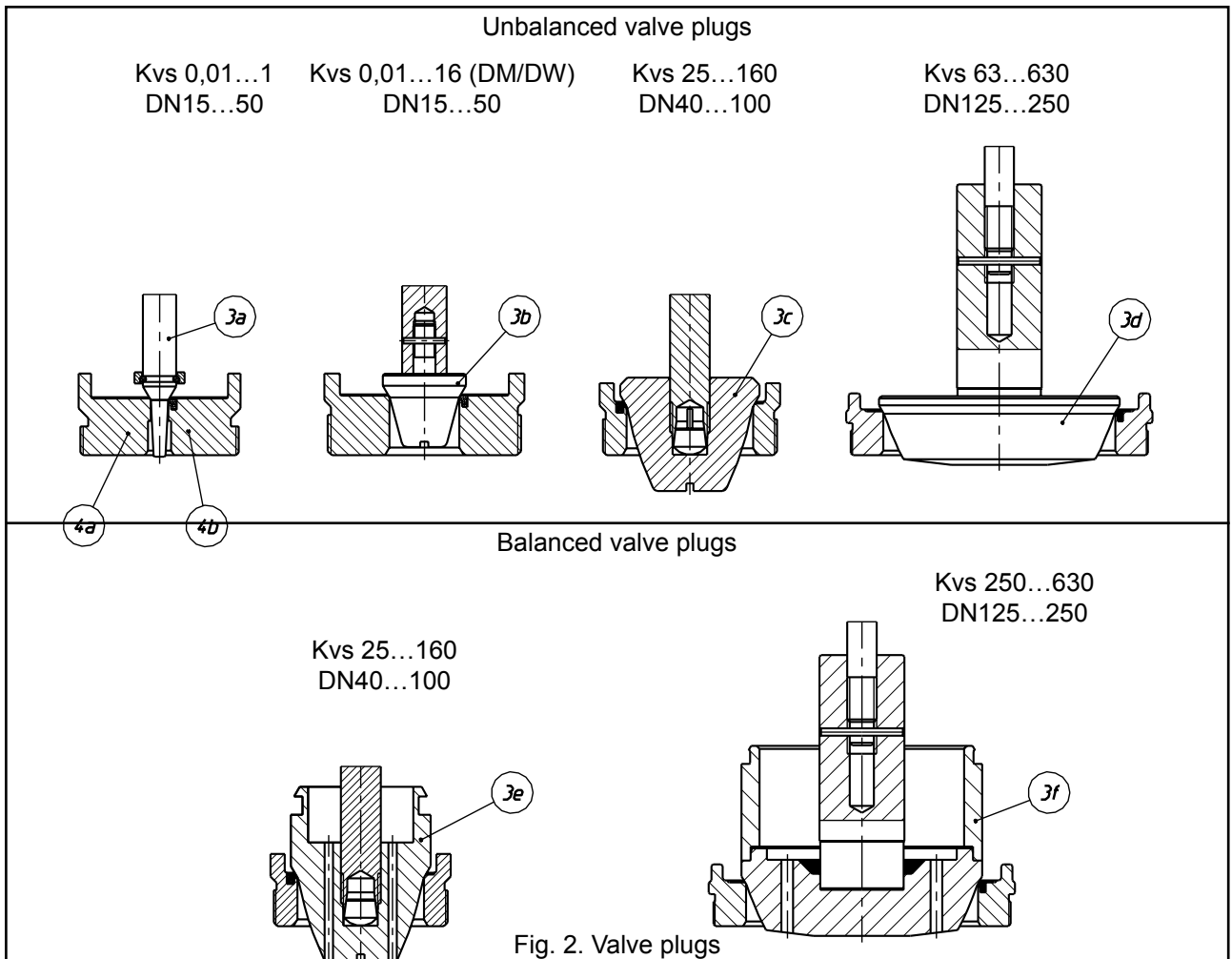

Fig. 2. Valve plugs

**Valve seat (4)** - screwed in, with centering cone, sealing and preventing unscrewing:

- hard version,
- soft version (PTFE packing).

**Valve plug stem (5)** - burnished or quenched and tempered, polished sealing contact surface

**Drain plug (6)** - steel or stainless steel: allows cleaning of body interior (delivered separately)

**Body gasket (7)** - asbestos-free:

- flat – aramid and hardened graphite (1.4571); in metallic casing (1.4571), multiple edges
- bonnet:
  - packings formed in various materials (PTFE-V; PTFE+graphite; expanded graphite; braided graphite);
  - with TA Luft compression springs (PTFE-V; graphite)

Table 2. Packing types with application ranges.

Packing	PN / CL	Temperature [°C]		
		Bonnet		
		Standard	Extension	Bellow
PTFE-V	PN10...CL300	-46...+200	-198...-46 +200...+300	-100...+200
PTFE + Graphite				
PTFE-V / TA-LUFT		+200...+300	+300...+450	+200...+400
Graphite				
Graphite / TA-LUFT				

**Leakage class:** - basic: Class IV as per PN-EN 60534-4 - hard valve seat  
 - bubble-tight Class VI as per PN-EN 60534-4 - soft valve seat

Table 3. Listing of components with materials

Item	Component	Materials					
		EN-GJL 250 (EN-JL 1040)	EN-GJS 400-18 LT (EN-JS 1025)	GP 240 GH (1.0619)	WCB	GX5CrNiMo 19-11-2 (1.4408)	CF8M
1	Body						
2	Bonnet	DN15...100	S 355 J2G3 (1.0570)			X6CrNiMoTi 17-12-2 (1.4571)	
		DN125...250	EN-GJL 250 (EN-JL 1040)	EN-GJS 400-18 LT (EN-JS 1025)	GP 240 GH (1.0619)	WCB	GX5CrNiMo 19-11-2 (1.4408)
3	Plug	X6CrNiMoTi 17-12-2; (1.4571) X6CrNiMoTi 17-12-2; (1.4571) + stellite + CrN X17CrNi 16-2; (1.4057) + heat treatment					
4	Seat	X6CrNiMoTi 17-12-2; (1.4571) X6CrNiMoTi 17-12-2; (1.4571) + stellite X6CrNiMoTi 17-12-2; (1.4571) + PTFE X17CrNi 16-2; (1.4057) + heat treatment					
5	Stem	X6CrNiMoTi 17-12-2; (1.4571) X6CrNiMoTi 17-12-2; (1.4571) + stellite + CrN X17CrNi 16-2; (1.4057) + heat treatment					
6	Drain plug	S 355 J2G3 (1.0570)				X6CrNiMoTi 17-12-2; (1.4571)	
7	Body gasket	in metal casing X6CrNiMoTi 17-12-2 (1.4571); NOVATEC PREMIUM; SIGRAFLEX HOCHDRUCK; MWK-50 SPETOMET					
8	Guiding sleeve	X6CrNiMoTi 17-12-2; (1.4571) + CrN X6CrNiMoTi 17-12-2; (1.4571) + stellite + CrN X17CrNi 16-2; (1.4057) + heat treatment					
9	Compression plate	C45 (1.0503); X30Cr13 (1.4028); X6CrNiMoTi 17-12-2; (1.4571)					
10	Bolt	8.8				A4 - 70	
11	Nut	8				A4 - 70	
12	Packing	PTFE + GRAFIT; PTFE - „V“; GRAPHITE					
13	Spring	12R10 (SANDVIK)					
14	O-ring	Fluorine rubber (FKM)					
15	Guiding sleeve	X6CrNiMoTi 17-12-2; (1.4571) + CrN X6CrNiMoTi 17-12-2; (1.4571) + stellite + CrN X17CrNi 16-2; (1.4057) + heat treatment					
16	Seal ring	PTFE + X6CrNiMoTi 17-12-2 (1.4571); TURCON + X6CrNiMoTi 17-12-2 (1.4571)					
17	Bellow	X6CrNiMoTi 17-12-2; (1.4571)					
Relevant materials standards							
Material		Standard					
EN-GJL 250; (EN-JL 1040)		PN-EN 1561					
EN-GJS 400-18 LT; (EN-JS 1025)		PN-EN 1563					
GP 240 GH; (1.0619)		PN-EN 10213-2					
WCB		ASTM A 216					
GX5CrNiMo 19-11-2; (1.4408)		PN-EN 10213-4					
CF8M		ASTM A 351					
S 355 J2G3; (1.0570)		PN-EN 10025					
X6CrNiMoTi 17-12-2; (1.4571)		PN-EN 10088					
X17CrNi 16-2; (1.4057)		PN-EN 10088					
C45 (1.0503)		PN-EN 10083-1					
X30Cr13 (1.4028)		PN-EN 10088					

**NOTE:**

Hardening method used for hardening of valve internal parts comprises:

- stelliting – padding of surfaces with stellite: ~40HRC
- CrN coating – introducing chromium nitride to external layer of detail, to the depth of ca.0.1 mm; ~950HV
- heat treatment: plug (~45HRC), seat (~35HRC), stem (~35HRC), guide sleeve (~45HRC)
- Maximum working temperature -200...+250°C (for KEFLOY 25 material), higher temperatures: upon consultation with the manufacturer.

Table 4. Working parameters for special executions of valves.

Valve execution	Working temperature [°C]		Max working pressure [bar]
	Min.	Max.	
With balanced plug	-50	+200	40
With soft valve seat (PTFE)	-100	+400	35
With bellow seal bonnet	-100	+400	35

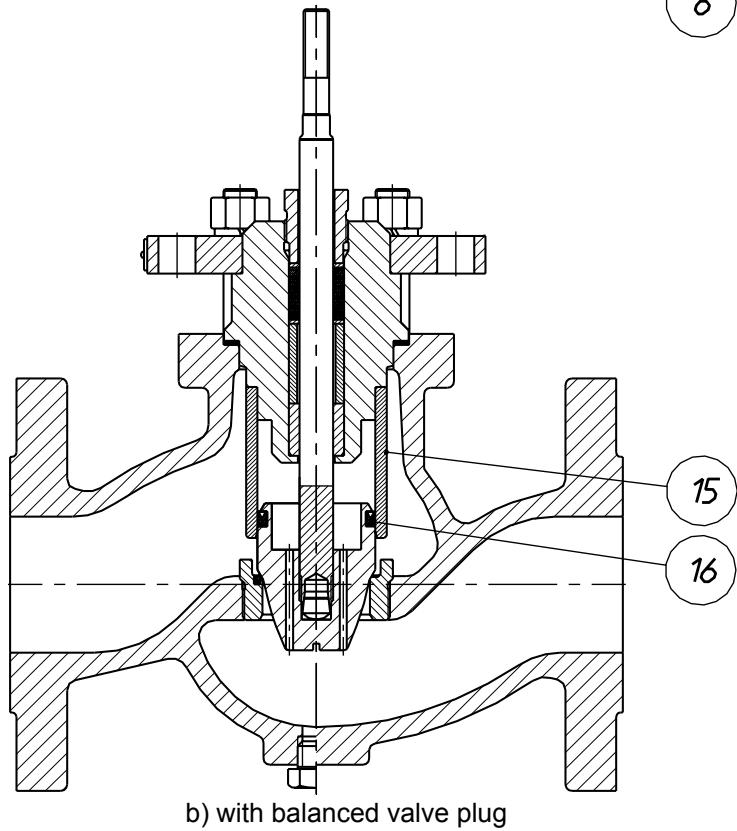
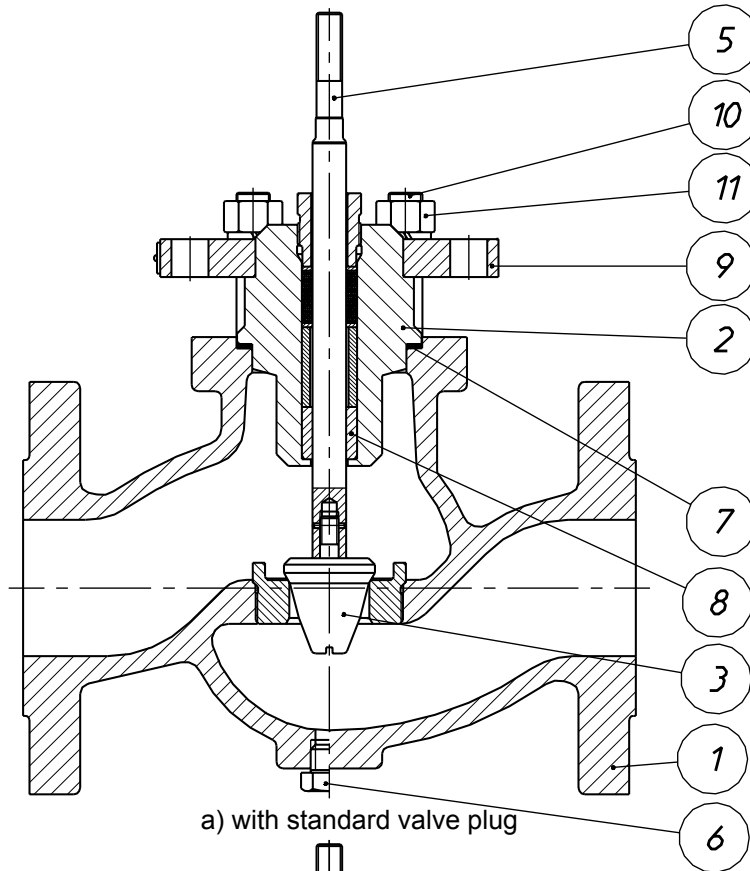
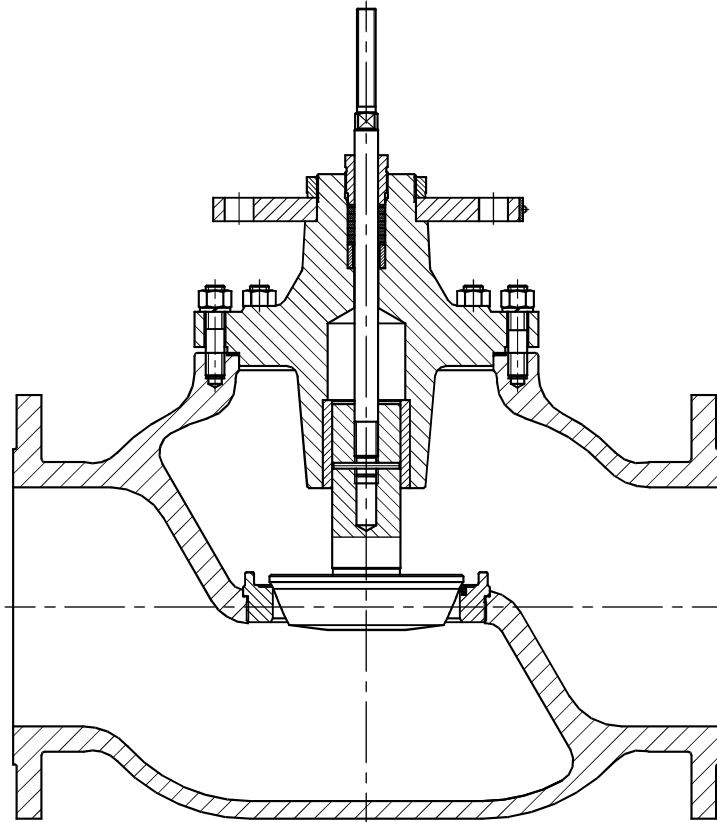
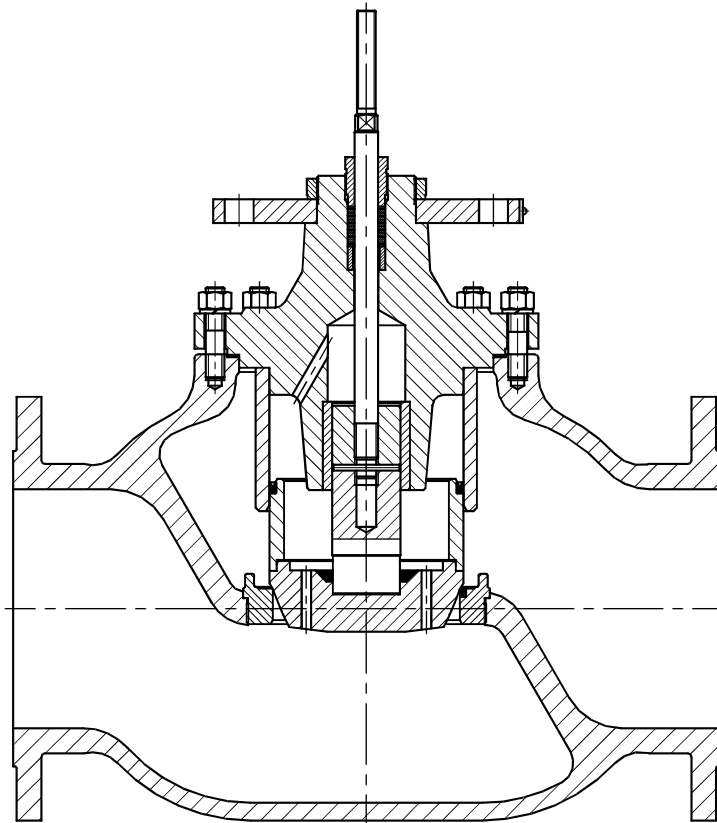

Fig. 3. Control valve DN15-100



a) with standard valve plug



b) with balanced valve plug

Fig. 4. Control valve DN125-250

Table 5...11. Allowable working overpressure for materials at proper temperatures

Table 5.		Material: EN-GJL 250 as per PN-EN 1561						
PN	Standard	Temperature [°C]						
		-10...120	150	180	200	230	250	300
		Allowable working pressure [bar]						
PN10	PN-EN 1092-2	10	9	8,4	8	7,4	7	6
PN16		16	14,4	13,4	12,8	11,8	11,2	9,6

Table 6.		Material: EN-GJS 400-18 LT as per PN-EN 1563					
PN	Norma	Temperature [°C]					
		-10...120	150	200	250	300	350
		Allowable working pressure [bar]					
PN10	PN-EN 1092-2	10	9,7	9,2	8,7	8	7
PN16		16	15,5	14,7	13,9	12,8	11,2
PN25		25	24,3	23	21,8	20	17,5
PN40		40	38,8	36,8	34,8	32	28

Table 7.		Material: GP240GH (1.0619) as per PN-EN 10213-2							
PN / CL	Norma	Temperature [°C]							
		-10...50	100	150	200	250	300	350	400
		Allowable working pressure [bar]							
PN10	EN 1092-1	10	9,2	8,8	8,3	7,6	6,9	6,4	5,9
PN16		16	14,8	14	13,3	12,1	11	10,2	9,5
CL150	PN-EN 1759-1	17,3	15,4	14,6	13,8	12,1	10,2	8,4	6,5
PN25	EN 1092-1	25	23,2	22	20,8	19	17,2	16	14,8
PN40		40	37,1	35,2	33,3	30,4	27,6	25,7	23,8
CL300	PN-EN 1759-1	45,3	40,1	38,1	36	32,9	29,8	27,8	25,7

Table 8.		Material: GX5CrNiMo 19-11-2 (1.4408) as per PN-EN 10213-4									
PN / CL	Norma	Temperature [°C]									
		-10...50	100	150	200	250	300	350	400	425	450
		Allowable working pressure [bar]									
PN10	EN 1092-1	10	10	9	8,4	7,9	7,4	7,1	6,8	-	6,7
PN16		16	16	14,5	13,4	12,7	11,8	11,4	10,9	-	10,7
CL150	PN-EN 1759-1	17,9	16,3	14,9	13,5	12,1	10,2	8,4	6,5	5,6	4,7
PN25	EN 1092-1	25	25	22,7	21	19,8	18,5	17,8	17,1	-	16,8
PN40		40	40	36,3	33,7	31,8	29,7	28,5	27,4	-	26,9
CL300	PN-EN 1759-1	46,7	42,5	38,9	35,3	32,9	30,5	28,8	27,6	27,2	26,9

Table 9.		Material: G20Mn5 (1.6220) wg PN-EN 10213-3					
PN / CL	Norma	Temperature [°C]					
		-40	100	150	200	250	300
		Allowable working pressure [ bar]					
PN10	-	6	6	3,8	3,6	3,48	3,4
PN16		16	16	10,1	9,6	9,28	9,07
PN25		25	25	15,8	15	14,5	14,2
PN40		40	28	28	27	26	25

Table 10.		Material: WCB as per ASTM A216								
PN / CL	Norma	Temperature [°C]								
		-10...50	100	150	200	250	300	350	375	400
		Allowable working pressure [bar]								
PN10	EN 1092-1	10	10	9,7	9,4	9	8,3	7,9	7,7	6,7
PN16		16	16	15,6	15,1	14,4	13,4	12,8	12,4	10,8
CL150	PN-EN 1759-1	19,3	17,7	15,8	14	12,1	10,2	8,4	7,4	6,5
PN25	EN 1092-1	25	25	24,4	23,7	22,5	20,9	20	19,4	16,9
PN40		40	40	39,1	37,9	36	33,5	31,9	31,1	27
CL300	PN-EN 1759-1	50	46,4	45,1	43,9	41,8	38,9	36,9	36,6	34,6

Table 11.		Material: CF8M as per ASTM A351										
PN / CL	Norma	Temperature [°C]										
		-10...50	100	150	200	250	300	350	375	400	425	450
		Allowable working pressure [bar]										
PN10	EN 1092-1	8,9	7,8	7,1	6,6	6,1	5,8	5,6	5,5	5,4	5,4	5,3
PN16		14,3	12,5	11,4	10,6	9,8	9,3	9	8,8	8,7	8,6	8,5
CL150	PN-EN 1759-1	18,4	16	14,8	13,6	12	10,2	8,4	7,4	6,5	5,6	4,6
PN25	EN 1092-1	22,3	19,5	17,8	16,5	15,5	14,6	14,1	13,8	13,6	13,5	13,4
PN40		35,6	31,3	28,5	26,4	24,7	23,4	22,6	22,1	21,8	21,6	21,4
CL300	PN-EN 1759-1	48,1	42,3	38,6	35,8	33,5	31,6	30,4	29,6	29,3	29	29

**NOTES:**

1. It is allowed to apply spheroidal iron, carbon steel and acid proof cast steel for temperatures lower than given in Tables 5...11, provided that working pressure is reduced respectively, working temperature impact tests are performed and cast is heat treated. Details are to be consulted with manufacturer.
2. Working pressure for intermediate temperature values can be calculated by interpolation.

Table 12. Flow ratios Kvs [m³/h] for unbalanced valve plugs

Kvs [m³/h]	Stroke [mm]	Valve seat diameter D [mm]	F <sub>D</sub> [kN]		Nominal size DN													Characteristics					
			Hard valve seat	Soft valve seat	15	20	25	32	40	50	65	80	100	125 <sup>*)</sup>	150	200	250	L	P	S			
0,010	20	6,35	0,1	0,16																			
0,016																							
0,025																							
0,040																							
0,063																							
0,10																							
0,16																							
0,25																							
0,40																							
0,63																							
1,0																							
1,6			9,52	0,15	0,25																		
2,5			12,7	0,2	0,3																		
4,0																							
6,3			19,05	0,3	0,5																		
10			20,64	0,35	0,5																		
16			25,25	0,4	0,6																		
25			31,72	0,5	0,8																		
40			41,25	0,7	1,0																		
63		38	50,8	0,8	1,3																		
94	66,7		1,1	1,7																			
125	88,9		1,4	2,2																			
160	50	107,92	1,7	2,7																			
250																							
320		126,95	2,0	3,2																			
500	63	158,72	2,5	4,0																			
630		195	3,1	4,9																			

Calculated ratios: F<sub>L</sub> = 0,9 ; X<sub>v</sub> = 0,72 ; F<sub>d</sub> = 0,46 ; xFz = 0,65

Table 13. Flow ratios Kvs [m³/h] for balanced valve plugs

Kvs [m³/h]	Stroke [mm]	Valve nominal size DN									Characteristics		
		40	50	65	80	100	125 <sup>*)</sup>	150	200	250	L	P	S
25	20												
40													
63	38												
94													
125													
160													
250	50												
320													
500	63												
630													

NOTE:

Valve seat diameter for balanced valve plug flow ratio Kvs 250 is 126.95 mm.

<sup>\*)</sup>DN125 - special execution, technical data according to individual inquiries.



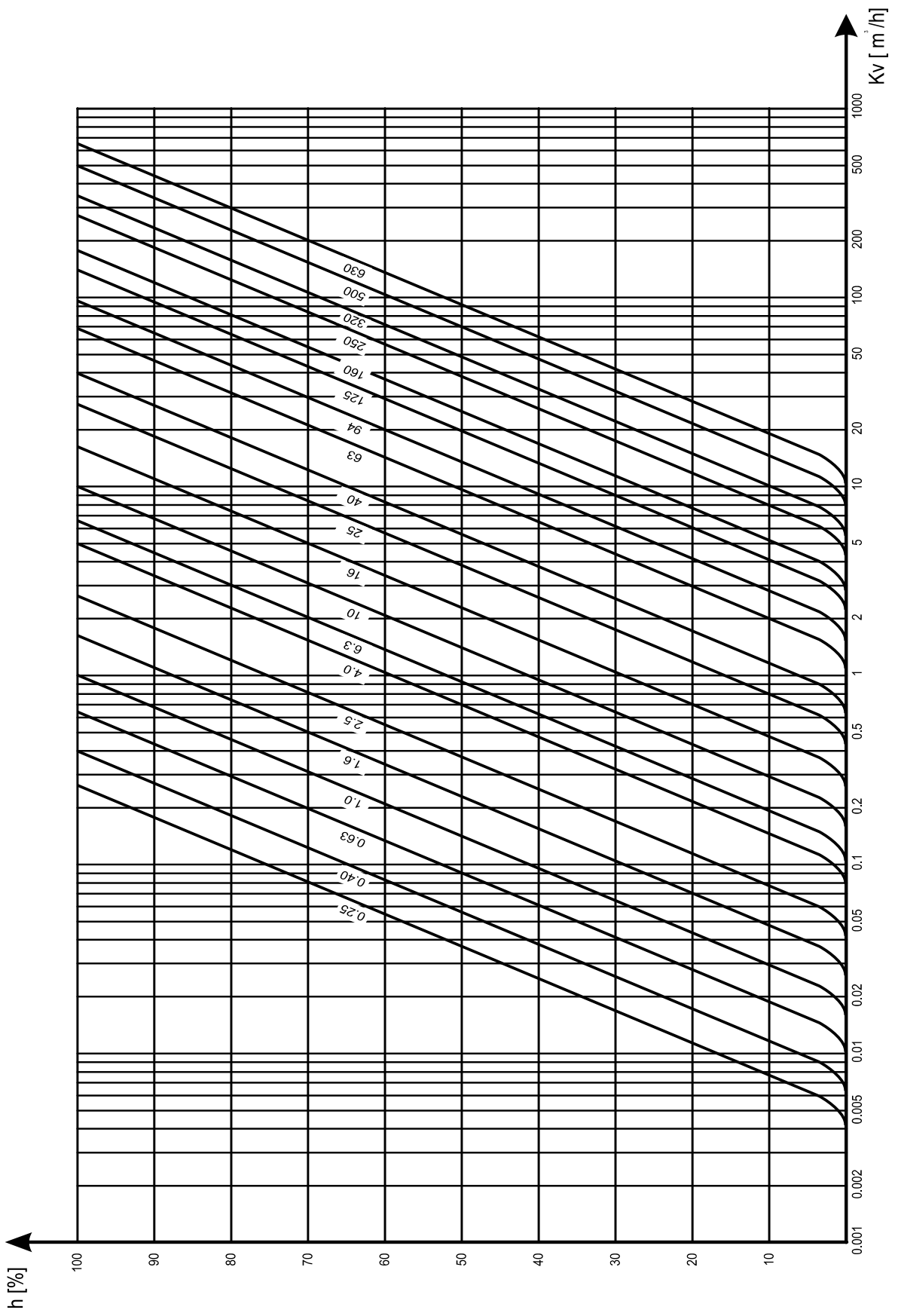

Diagram 1. Equal percentage flow characteristics for control valves  $Kvs=0.25 \dots 630 \text{ m}^3/\text{h}$

**ALLOWABLE PRESSURE DROPS  $\Delta p$ .**

Pressure drops  $\Delta p$  [bar] in Tables 15 and 16 apply to closed valve and they are calculated for valve drive potential. Actual pressure drops should not exceed 70% of allowable working pressure for given nominal pressure, material execution and working temperature, as per tables 5...11.

$$\Delta p = \frac{F_s - F_D}{0,785 \cdot 10^{-4} \cdot D^2} \quad \text{or} \quad F_s = 0,785 \cdot 10^{-4} \cdot D^2 \cdot \Delta p + F_D$$

where  $\Delta p$  [bar] - calculated pressure drop  
 $F_s$  [kN] - actuator available force (Table 14)  
 $F_D$  [kN] - valve plug to valve seat pressure (Table 12)  
 $D$  - valve seat diameter [mm] (Table 12)

Table 14. Available force  $F_s$  [kN] of pneumatic actuators

Actuator size	Direct actuator P			Reverse actuator R					
	Supply pressure [kPa]			Spring range [kPa]					
	140	250	400	20 - 100	40 - 120; 40 - 200	60 - 140	80 - 240	120 - 280	180 - 380
160	0,64	2,4	4,8	0,32	0,64	0,96	1,28	1,92	-
250	1,0	3,8	7,5	0,5	1,0	1,5	2,0	3,0	-
400	1,6	6,0	12,0	0,8	1,6	2,4	3,2	4,8	-
630	2,5	9,5	18,9	1,3	2,5	3,8	5,0	7,6	11,3
1000	4,0	15,0	30,0	2,0	4,0	6,0	8,0	12,0	18,0

**NOTE:**

1. For direct actuators P adopted spring range is 20 – 100 kPa
2. For electric and other actuators  $\Delta p$  value can be calculated using above formula and data from Tables 12 and 14, taking nominal load capacity as available force  $F_s$ , as per actuator catalog chart.
3. For balanced valve plugs available force  $F_s$  at least equal to  $F_D$  value for soft valve seats in Table 12 should be adopted.

Table 15. Allowable pressure drops  $\Delta p$  [bar] for valves with unbalanced valve plugs and hard valve seats, with pneumatic actuators.

Flow ratio Kvs [m³/h]	Valve nominal diameter DN	Stroke [mm]	Air – to – close					Air – to – open		
			Actuator		$\Delta p$ [bar]			Actuator		$\Delta p$ [bar]
			Size	Spring range [kPa]	Supply pressure [kPa]			Size	Spring range [kPa]	
					140	250	400			
do 4	15; 20; 25; 32; 40; 50	20	160	20-100	34	-	-	160	20-100	9
6,3	20; 25; 32; 40; 50				11	40	-		40-200	34
10	25; 32; 40; 50				9	40	-		20-100	7
16	32; 40; 50				4	40	-		40-200	11
					40	-	-		60-140	23
									80-240	28
									120-280	30
do 4	15; 20; 25; 32; 40; 50				250	20-100	40		-	-
6,3	20; 25; 32; 40; 50		24	40			-	40-200	40	
10	25; 32; 40; 50		20	40			-	20-100	7	
16	32; 40; 50		12	40			-	40-200	24	
								60-140	40	
								80-240	40	
			120-280	40						
25	40; 50; 65; 80		24	40			-	20-100	5	
					40-200	20				
40	50; 65; 80; 100; 125	400	20-100	20-100	8,5	40	-	630	60-140	34
									180-380	40
									40-200	6
									60-140	12
63	65; 80; 100; 125	38	20-100	20-100	16	40	-	1000	80-240	18
									120-280	29
									40-200	9
									60-140	15
94	80; 100; 125	630	20-100	20-100	4	24	40	630	80-240	8
									120-280	11
									180-380	18
									40-200	29
125; 160	100; 125	1000	20-100	20-100	8	32	40	1000	80-240	8
									120-280	20
									180-380	31
									40-200	40
250	150; 200; 250	630	20-100	20-100	2	13	28	630	80-240	2
									120-280	4
									180-380	6
									40-200	10
320	150; 200; 250	50	20-100	20-100	4	22	40	1000	80-240	4
									120-280	10
									180-380	17
									40-200	26
500	200; 250	63	20-100	20-100	2,5	14	30	1000	80-240	2,5
									120-280	6,5
									180-380	11
									40-200	17,5
630	250	1000	20-100	20-100	1,5	10	22	1000	80-240	1,5
									120-280	4,5
									180-380	8
									40-200	12,5
500	200; 250	63	20-100	20-100	-	6	14	1000	80-240	-
									120-280	2,5
									180-380	5
									40-200	7,5
630	250	1000	20-100	20-100	-	4	9	1000	80-240	-
									120-280	1,5
									180-380	3
									40-200	5

<sup>1)</sup>DN125 - special execution, technical data according to individual inquiries.

- Note:**
- In Table 15, theoretical acceptable pressure drops are included. Actual pressure drops with consideration of tolerance of spring manufacture and friction of internal parts of the actuator are lower than those given by 20%. Pressure drops chosen that way guarantee internal tightness of closing of the valves.
  - In air-to-open valves actuator with spring range of 40-200 [kPa] can be replaced with actuator with spring range of 40-120 [kPa], at the same pressure drops.
  - In valves with balanced valve plugs and hard valve seats for pressure drops up to  $\Delta p=40$  [bar], actuators are to be selected as below:
    - for air-to-close action: spring range 20-100 [kPa], supply pressure 140 [kPa]
    - for air-to-open action: spring range 40-120 [kPa], or 40-200 [kPa]

Table 16. Allowable pressure drops  $\Delta p$  [bar] for valves with unbalanced valve plugs and soft valve seats, with pneumatic actuators.

Flow ratio Kvs [m <sup>3</sup> /h]	Valve nominal diameter DN	Stroke [mm]	Air – to – close					Air – to – open								
			Actuator		$\Delta p$ [bar]			Actuator		$\Delta p$ [bar]						
			Size	Spring range [kPa]	Supply pressure [kPa]			Size	Spring range [kPa]							
					140	250	400									
do 4	15; 20; 25; 32; 40; 50	20	160	20-100	25	-	-	160	20-100	-						
6,3	20; 25; 32; 40; 50				5	35	-		40-200	25						
10	25; 32; 40; 50				3	35	-		60-140	5						
16	32; 40; 50				-	35	-		80-240	16						
					35	-	-		40-200	3						
					17	35	-		60-140	13						
					12	35	-		80-240	22						
do 4	15; 20; 25; 32; 40; 50				250	20	35		-	-	250	40-200	-			
6,3	20; 25; 32; 40; 50		6				35	-	60-140	6						
10	25; 32; 40; 50		18				35	-	80-240	12						
16	32; 40; 50		6				35	-	120-280	25						
			10				35	-	20-100	15						
			3,5				35	-	40-200	35						
			17				35	-	60-140	17						
25	40; 50; 65; 80		400				20	10	35	-		400	80-240	35		
40	50; 65; 80; 100; 125				18			35	-	120-280	6					
		6		35	-			60-140	16							
		3		23	35			80-240	26							
		7		35	-			120-280	35							
63	65; 80; 100; 125	10		35	-			180-380	35							
		3,5		35	-			40-200	3,5							
		6		35	-			60-140	9							
		13	35	-	80-240			15								
94	80; 100; 125	6	35	-	120-280	26										
		13	35	-	180-380	35										
		3	23	35	40-200	13										
		7	35	-	60-140	7										
125; 160	100	630	38	20-100	-	11		26	630	80-240	10					
		1000			7	35		-		120-280	18					
		630			7	35		-		180-380	28					
		1000			40-200	7										
250	150; 200; 250	630			50	20-100	-	11	26	630	60-140	2				
		1000					7	35	-		80-240	4				
		630					7	35	-		120-280	8				
		1000					40-200	7								
320	150; 200; 250	630					63	20-100	2,5	20	35	630	180-380	14		
		1000							2,5	20	35		40-200	2		
		630							1,2	13	29		60-140	9		
		1000							1,2	13	29		80-240	15		
500	200; 250	630							50	20-100	-	9	21	630	120-280	10
		1000									7	35	-		180-380	16
		630									7	35	-		40-200	1
		1000									40-200	7				
630	250	630	63	20-100							-	5	8	630	80-240	5
		1000									7	35	-		120-280	10
		630									7	35	-		180-380	16
		1000									40-200	7				
630	250	630			63	20-100					-	3	8	630	40-200	-
		1000									7	35	-		60-140	3,5
		630									7	35	-		80-240	6,5
		1000									40-200	7				
630	250	630					63	20-100			-	3	8	630	120-280	2
		1000									7	35	-		180-380	4
		630									7	35	-		40-200	-
		1000									40-200	7				

<sup>1)</sup>DN125 - special execution, technical data according to individual inquiries.

**Note:**

1. In Table 16, theoretical acceptable pressure drops are included. Actual pressure drops with consideration of tolerance of spring manufacture and friction of internal parts of the actuator are lower than those given by 20%.  
Pressure drops chosen that way guarantee internal tightness of closing of the valves.
2. In air-to-open valves actuator with spring range of 40-200 [kPa] can be replaced with actuator with spring range of 40-120 [kPa], at the same pressure drops.
3. In valves with balanced valve plugs and soft valve seats for pressure drops up to  $\Delta p=35$  [bar], actuators are to be selected as below:
  - for air-to-close action: spring range                      20-100 [kPa], supply pressure 140 [kPa]
  - for air-to-open action: spring range                      40-120 [kPa], or 40-200 [kPa]
4. For rotary actuators – R, supply pressure is to be 40 kPa higher than upper spring range [kPa].

**VALVE DRIVES:****1. Diaphragm multi-spring pneumatic actuators w/o manual drive type P/R or with top-mounted handweel type P/R-N – as per Tables 17 and 20.**

Table 17. Pneumatic actuators

Size	Diaphragm effective area [cm <sup>2</sup> ]	Stroke [mm]	Rev per rated stroke (P/R-N)
160	160	20	5
250	250	20	5
400	400	20	5
630	630	38	9
1000	1000	38; 50; 63	8; 10; 13

**CHARACTERISTICS:**

- complete reversibility of operation allows changing function P (direct action) and R (reverse action) with no additional parts,
- option of changing spring range (tension) with no additional parts,
- option of pre-tensioning of springs,
- option of fitting with top-mounted handweel.

**DESIGN AND TECHNICAL SPECIFICATION:**

As per Fig. 5.

**CONSTRUCTION:**

Actuator diaphragm cases (1) and (2) of steel sheets making pressure chamber

Diaphragm (3) of constant effective area, linear relationship between control actuator pressure and plug movement. Executed in neoprene with polyester spacer.

Diaphragm plate (4) stamped from steel sheet, with spring seats.

Support (6) is used for tightening and operating the stem.

Springs (7) of construction spring steel. There are 3, 6 or 12 springs regarding the required range.

Bushing (8) and spacers (9) – used for altering actuator action from direct to reverse and altering spring range.

Warning plates (10) with information on safe disassembly.

**TECHNICAL SPECIFICATION:**

Control air connection: NPT 1/4", NPT 1/2"

Pipe diameter:  $\varnothing$  6x1,  $\varnothing$  8x1,  $\varnothing$  10x1,  $\varnothing$  12x1

Spring ranges:	20...100 kPa; 40...120 kPa; 60...140 kPa	- 3 springs,
	40...200 kPa; 80...240 kPa; 120...280 kPa	- 6 springs,
	180...380 kPa	- 12 springs; (only sizes 630-1000).

Max supply pressure: actuator size 160...630 - 600 kPa, for actuator size 1000 - 500 kPa.

Actuator ambient temperature range: -40...+80°C

Optional accessories:

- top-mounted handweel,
- pneumatic positioner,
- electro-pneumatic positioner,
- air-set,
- three-way solenoid valve,
- lock-up,
- limit switches,
- quick exhaust valve.

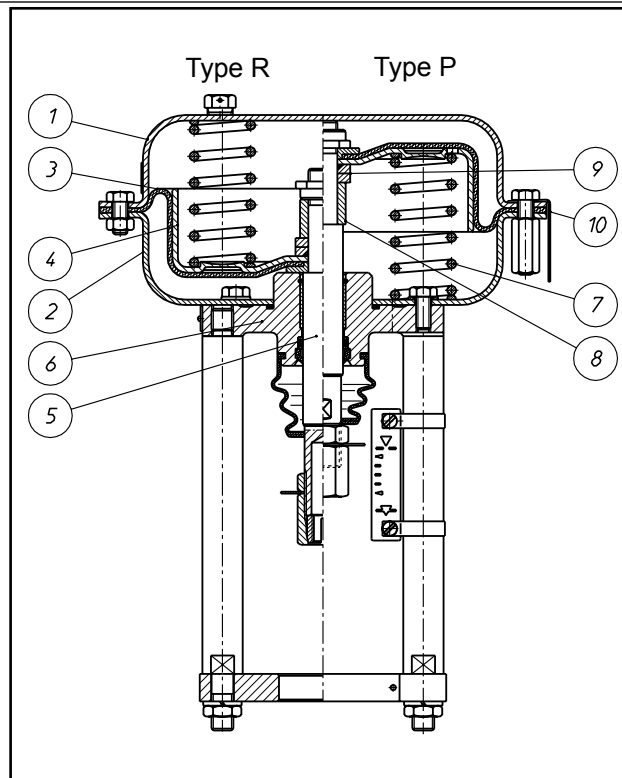

Fig. 5. P/R multi-spring actuator

## 2. Electric actuators

There is a possibility of employing any electric or electro-hydraulic actuator following adjustment of connecting elements. Details and technical specifications of electric actuators as per separate catalog charts.

## 3. NN manual drives

Drives allowing manual operation of valve, adapted to direct assembly on valve (with no extra parts).

Table 18. Drive sizes.

Size	Stroke [mm]	Rev per rated stroke
250	20	5
400	20	5
630	38	9
1000	38; 50; 63	8; 10; 13

## EXTERNAL DIAMETERS AND CONNECTION DIAMETERS, WEIGHTS OF VALVES, PNEUMATIC ACTUATORS AND MANUAL DRIVES

Table 19. Valve connection diameters [mm]

DN	$d_1$	$d_3$	E	L	$L_1$	P	R
15...25	M12x1,25	12	44	125	111	12,5	110
32...50				118	102	16,5	132
65...100		16		122	104	16,5	132
125...250		M16x1,5		20	95	200	180
	80		138		118	24,5	216

### Note:

- 1) R and  $\varnothing P$  can be as per customer request
  - 2) R=160 - for electrical actuators
  - 3) L and  $L_1$  - for valve plug location – valve closed
  - 4) L=138 - for electric actuators
- \*DN125 - special execution, technical data according to individual inquiries.

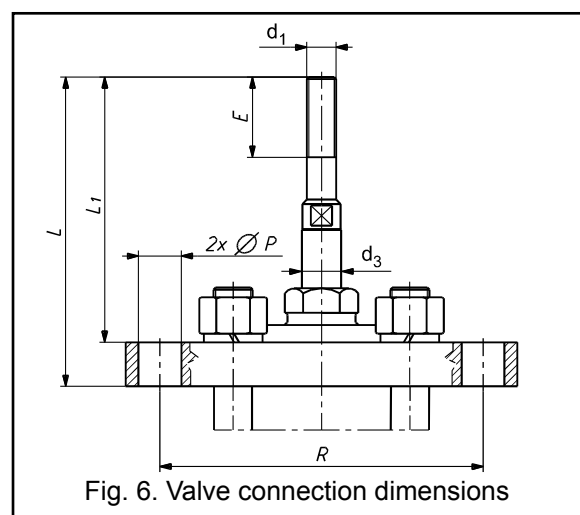

Fig. 6. Valve connection dimensions

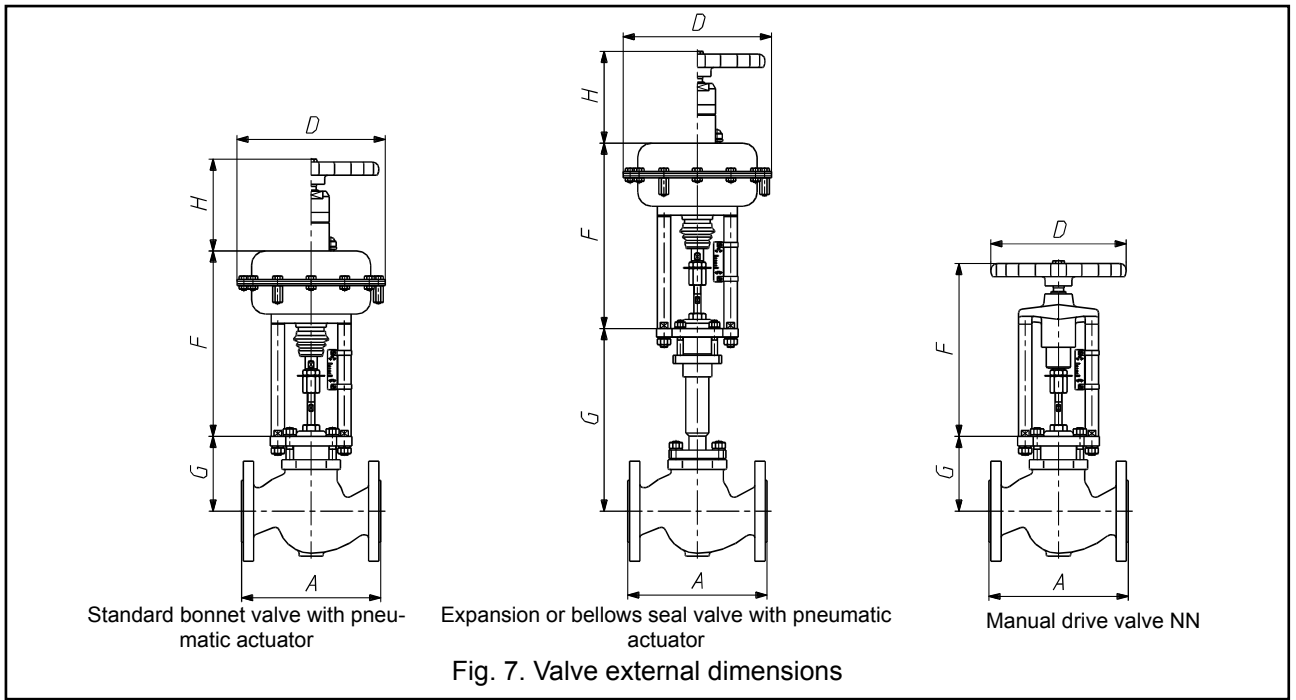

Table 20. Valve dimensions incl. drives [mm].

DN	A			G		F										D					H			
	CL150	CL300	PN10...40	Standard bonnet.	Ext. and bellows seal bonnet	P/R 160	P/R 250	P/R 400	P/R 630	P/R 1000	NN 250	NN 400	NN 630	NN 1000	P/R 160	P/R 250	P/R 400	P/R 630	P/R 1000	NN 250		NN 400	NN 630	NN 1000
15	184	190	130	107	241	288	306	-	-	-	290	-	-	-	210	240	-	-	-	225	-	-	-	162
20	184	194	150	107	241	288	306	-	-	-	290	-	-	-	210	240	-	-	-	225	-	-	-	162
25	184	197	160	107	241	288	306	-	-	-	290	-	-	-	210	240	-	-	-	225	-	-	-	162
32	200	213	180	114	243	288	306	-	-	-	290	-	-	-	210	240	-	-	-	225	-	-	-	162
40	222	235	200	118	253	288	306	312	-	-	290	290	-	-	210	240	305	-	-	225	225	-	-	162
50	254	267	230	122	257	288	306	312	-	-	290	290	-	-	210	240	305	-	-	225	225	-	-	162
65	276	292	290	166	410		-	312	402	-	-	290	308	-	-	305	375	-	-	225	305	-	-	162
80	298	317	310	166	410		-	312	402	-	-	290	308	-	-	305	375	-	-	225	305	-	-	162
100	352	368	350	173	417		-	312	402	-	-	290	308	-	-	305	375	-	-	225	305	-	-	162
125	special execution, technical data according to individual inquiries.																							
150	451	473	480	305	510		-	-	-	585	-	-	-	510		-	-	-	477	-	-	-	450	240
200	543	568	600	458	623		-	-	-	585	-	-	-	510		-	-	-	477	-	-	-	450	240
250	673	708	730	475	623		-	-	-	585	-	-	-	510		-	-	-	477	-	-	-	450	240

**Note:** Dimension A for CL150 and CL300 refers to bodies with valve face B or RF. For other body versions you can calculate A<sub>1</sub> dimension using formulas in Table 21.

Table 21.

Body	Marking		A <sub>1</sub>
	PN	ANSI	
Groove CL300	D1	GF	A <sub>1</sub> = A + 5 × 2
Recess CL300	F1	FF	A <sub>1</sub> = A + 5,5 × 2
Ring-joint CL300 DN15	J	RTJ	A <sub>1</sub> = A + 6,5 × 2
Ring-joint CL150			
Ring-joint CL300 DN20...40			
Ring-joint CL300 DN50...250			A <sub>1</sub> = A + 8 × 2

Table 22. Valve weights w/o drives [kg].

DN	Valve	
	Standard bonnet	Extended and bellows seal bonnet
15	6	9
20	7	10
25	7,5	11
32	9,5	13
40	11,5	16
50	14,5	20
65	20	28
80	28,5	36,5
100	42	50
125	110	135
150	120	135
200	180	195
250	320	335

Table 23. Actuator weights [kg]

Actuator	Weight
P / R - 160	9
P / R - N - 160	13,5
P / R - 250	10
P / R - N - 250	14,5
P / R - 400	16
P / R - N - 400	20,5
P / R - 630	30
P / R - N - 630	37
P / R - 1000	74
P / R - N - 1000	100

Table 24. Manual drive weights [kg]

Drive	Weight
NN - 250	5,5
NN - 400	6,5
NN - 630	8,5
NN - 1000	40

**PARTITION AND MARKING**



**Type and action:**

- pneumatic with direct action:	<b>P</b>
- pneumatic with reverse action:	<b>R</b>
- pneumatic with top manual drive:	<b>PN; RN</b>
- electric:	<b>E</b>
- manual:	<b>NN</b>

**Bonnet:**

- standard:	<b>1</b>
- extension:	<b>2</b>
- bellow seal:	<b>3</b>
- other:	<b>X</b>

**Packing:**

- PTFE, braided	<b>A</b>
- PTFE, typ V	<b>B</b>
- PTFE, for oxygen	<b>C</b>
- graphite, braided	<b>D</b>
- graphite, expanded	<b>E</b>
- TA-Luft, PTFE	<b>F</b>
- TA-Luft, graphite	<b>G</b>

**Leakage class:**

- basic: class IV	<b>4</b>
- bubble: class IV	<b>6</b>

**Valve plug:**

- unbalanced	<b>7</b>
- balanced	<b>8</b>

**Choke cages:**

- no choke cages	<b>0</b>
------------------	----------

**Plug characteristics and type:**

- linear, contoured	<b>L</b>
- equal percentage	<b>P</b>
- quick-opening, (on-off)	<b>S</b>
- other	<b>X</b>

**Body material:**

- grey iron	<b>1</b>
- spheroidal iron	<b>2</b>
- carbon steel	<b>3</b>
- stainless steel	<b>5</b>
- other	<b>X</b>

**MARKING EXAMPLE:**

Control valve type S with reverse action pneumatic actuator with top-mounted handweel, extension bonnet, expanded graphite stem sealing, leakage class IV, equal percentage contoured plug, execution in stainless steel:

**RN-S-2E470P5**

Marking is shown on valve nameplate.

**Additional information:**

- nominal size [DN],
- nominal pressure [PN],
- max working temperature [TS],
- max working pressure [PS],
- test pressure [PT],
- flow ratio [Kvs],
- plug stroke [H],
- plug stroke fluid group [1 or 2],
- serial number and year of manufacture.

**ORDERING:**

The order should contain all information as per data questionnaire. Full information can be obtained from the Sales and Marketing Department or Technical and Development Department.